

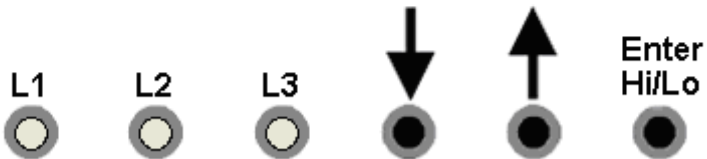

# EInet LTE

Energy Meter & Electrical Powermeter

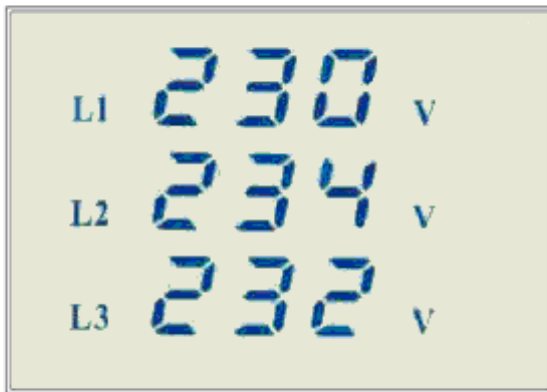

## EInet LTE Energy Meter & Electrical Powermeter

### Operating Instructions

Revision 1.1



Dear customer ,  
Thank you for choosing the ELNET LTE Powermeter for measuring energy , voltage , current , power and power factor .

## **1.1 Current transformer ratio setting**

Press the Enter button for about 6 seconds. A screen will appear and the user will be requested to enter a password (COD). Using the "↑" button, please change the number to "1" and then press Enter . The message "SET" will appear on the screen; please press Enter .

On the second line on the screen you will see the secondary value of the current transformer (5A) and on the third line, using the "↑ ↓" buttons; you should define the value of the current transformers. please press Enter .

Please use the "↑" button until you see the message "End" on the screen and then press Enter .

## 1.2 — Voltage transformer ratio setting

Press the Enter button for about 6 seconds. A screen will appear and the user will be requested to enter a password (COD). Using the "↑" button, please change the number to "1" and then press Enter. The message "Set A" will appear on the screen. Please use the "↑" button until you see "Setv" on screen and then press Enter.

On the second line on the screen you will see the secondary value of the voltage transformer (110V) and on the third line, using the "↑ ↓" buttons; you should define the value of voltage transformers. When finished, please press Enter.

Please use the "↑" button until you see the message "End" on screen and then press Enter.

## 1.3 — Measured values display

Using the "↑ ↓" buttons (each time you press it will circularly replace the screens) it is possible to browse through all display screens including the three-phase display of energy, voltage, current, power, frequency and power factor and the integrated screens of voltage, current and power factor for each phase.

## **1.4 — Peak display**

Pressing the Hi/Lo button (each time you press it will circularly replace the screens) will enable you to browse through the screens specifying the peak of voltage and current those were ever measured for each phase. The first screens display the highest values of voltage and current (Hi) measured; the next screens display the lowest values of voltage and current (Lo) measured, and then respectively high and low frequency and the power factor for each phase.

## **1.5— Indication LED**

The indication LED easily enables the user to identify whether there is voltage in phases L1, L2, L3. In case there is voltage in phase connections, the LED will turn on (at least 50 VAC).

## **1.6 — No volt & phase order alarm relay (option)**

When the voltage is proper (above 50VAC, adjustable) and the phase order is proper, the alarm relay will be closed, as it appears in the wiring diagram. The maximum current possible to transfer through this relay is 150ma, which is enough to operate a regular control relay.

To set the minimum voltage value for the no volt alarm, and to enable / disable the alarms relay in case of phase disorder please read paragraph 5.0 General Setting.

## 1.7 — Mechanical installation

**Comment:** Please do not install the ELNET LTE Powermeter close to electrical bars.  
Please leave enough space to approach the device from its back side for technical support.

Please choose the proper place for installation in the panel and prepare a square hole according to Figure 2.1.

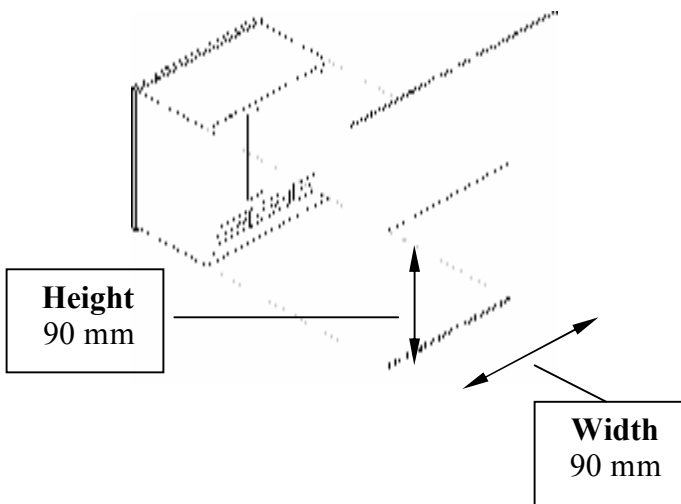
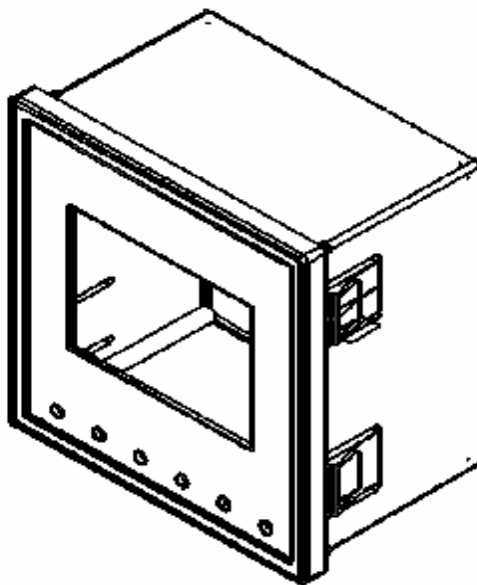

Figure 2.1: Space in the electrical panel



Please insert the ELNET LTE Powermeter into the suitable space prepared in advance. Make sure you insert the device in the right direction. The device is equipped with a plastic knob for adjustment when installed in electrical panels. The thickness of the panel door should be less than 4mm.





## 1.8 — Wiring diagram

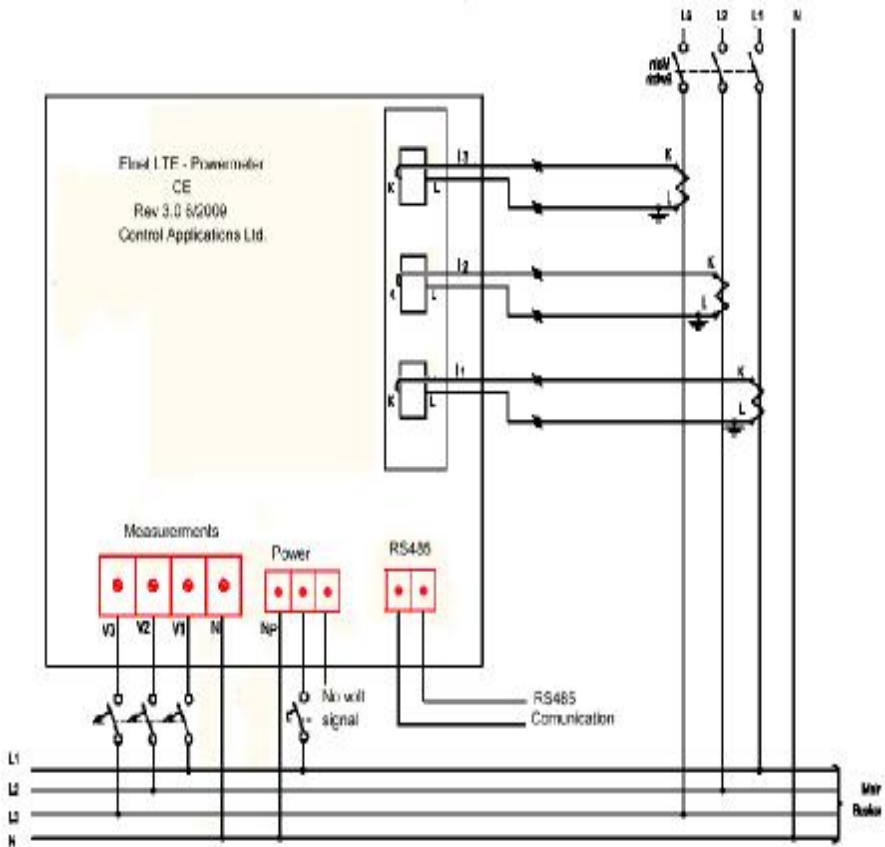

## 2.0 — MODBUS Protocol

The *EINet LTE* Energy & Power Multimeter has a serial interface port allowing direct interface with an external communication network supporting the MODBUS Protocol.

MODBUS is an Industry Standard, widely known and commonly used communications protocol. Using MODBUS provides communication between a PC and up to 247 Powermeter slaves on a common line - the PC being the master and the powermeters the slaves. The PC initiates the transaction (either a query or broadcast) and the Powermeter(s) responds. Powermeters respond to the master PC's request, but will not initiate any transmission on its own. The PC sends a single Query transaction and the Powermeter responds in a single response frame and is capable of only one query and one response at a time.

### 2.1 — MODBUS Framing

MODBUS uses the standard Remote Terminal Unit (RTU) transmission mode. RTU mode sends data in 8-bit binary with or without parity bit data format. For the *EINet LTE*



Energy & Power Multimeter to successfully communicate, choose "1" in the communication Set Up.

Field	No. of bits
Start bit	1
Data bits	8
Parity	1
Stop it	1

### RTU Data Format

#### 2.2 —RTU Frame Format

Query and response information is sent in frames. Each frame contains: Address; Function; Data; Check

	Address	Function	Data	Check
RTU	8 bits	8 bits	N * 8 bits	16 bits

#### Message Frame Format

If the receiving device (Powermeter) detects a time laps of five characters, it will assume the message is incomplete and will flush the frame. The device then assumes that the next byte received will be an address. The maximum query and response message length is 256 bytes including check characters.

### 2.3 — Address Field

Each Powermeter is designated in a network system by a user assigned address. The Address can be any number between 1 and 247. The Powermeter will only respond to its own specifically assigned address.

### 2.4 — Function Field

The function field contains the code that tells the Powermeter what action to perform.

The *EINet LTE* Energy & Power Multimeter uses and responds to four standard Message Format Functions.

Function Codes : 03;04;06;16

Function	Meaning in MODBUS	Action
Function 03	Read holding register	Obtain data from Powermeter
Function 04	Read input register	Obtain data from Powermeter (Read register)
Function 06	Preset single register	Transmit data to Powermeter (Write single register)
Function 16	Preset multiple register	Transmit data to Powermeter (Write multiple register)

## **2.5 — Data Field**

The Data field contains the body of the message and contains instructions from the PC master to the Powermeter slave to perform a particular action or respond to a query. The reply message from the Powermeter will be information contained in one or more of its registers.

## **2.6 — Check Field**

The error check field contains the result of the Cyclical Redundancy Check (CRC). The beginning of the message is ignored when calculating the CRC.

For more detailed information on CRC, refer to the MODBUS Protocol Reference Guide.

## **3.0 — Registers for EInet LTE Powermeter**

The *EInet LTE* Energy & Power Multimeter is capable of supporting either the Function 03 or Function 04 Message Format. In a reply to a query from the PC master for a reading from a particular field, the response from the Powermeter can be either in Format 03 or Format 04 but will depend on the Format the query was originally sent in.

The difference is significant because when using Function 03, the EInet LTE will only send the INTERGER part of the field value requested and the PCmaster will only display the INTERGER part of the field value.

On the other hand, Function 04 is capable of sending two separate halves of the full FLOAT requested information (each half contained in a separate register). Then it is the task of the PC master to merge the two halves into a full FLOAT reply (For more detailed information See IEEE Standard 754 Floating-Point).

E.G. 1 If the user's PC master supports Function 03, then the reply will contain the INTERGER part of the field only.

The PC master requests the Voltage rom Line1, and the actual Voltage in that field is 230.5 Volts. Function 03 will respond with the INTERGER only i.e.230V.

E.G. 2 If the user PC master supports Function 04, then the reply will contain the information stored in the two registers assigned to that field and will contain the full and accurate reply.

The PC master requests the Voltage from Line1, and the actual Voltage in that field is 230.5 Volts.

Function 04 will respond with a composite reply of both register 1 and 2 giving the fullFLOAT value (in IEEE Format) from that field i.e. 230.5V.

### 3.1 — Register addresses

The *EINet LTEMODBUS* registers addresses are updated from time to time and can be downloaded from the following web site:

[http://www.ddc.co.il/elnet-pdf/elnet\\_comm.pdf](http://www.ddc.co.il/elnet-pdf/elnet_comm.pdf)

## 4.0 — Communication Settings

To enable the *User* to connect the *EINet LTE* Energy & Power Multimeter to a PC for successful communications, both Communication Setup parameters must match; i.e. the PC port and the configuration settings of the Power meter, Address, Baud Rate, Parity must match.

### 4.1 — Communication Address

Each Power meter in a communication system must have its own unique address. Because the *EINet LTE* Energy & Power Multimeter works on MODBUS, the available addresses are - from '1' to '247'.

### 4.2 — Baud Rate

The Baud Rate is the communication speed in Bits per second (BPS) the *EINet LTE* Energy & Power Multimeter communicates with, with the PC. The better the communication line Quality, the faster the communications may be.

If the communication line is routed through a "noisy" environment, it may be necessary to decrease the Baud Rate.

Available Baud Rates for the *EINet LTE* Multimeter are as follows:

300; 600; 1200; 2400; 9600; 19200bps

### 4.3 — Parity

The choices of parity are either ODD, NONE or EVEN.

### 5.0 — General Settings

To set up Communications & Alarms

Press the Enter button for about 6 seconds. A screen will appear and the user will need to enter a password (COD). Using the "↑" button, please change the number to "2" and press Enter. The message "SET" will appear on the screen. On the second line, you will find the functions that need setting:

- |                             |                            |
|-----------------------------|----------------------------|
| 1. Address                  | will be displayed as "Adr" |
| 2. Baud rate                | will be displayed as "bud" |
| 3. Communication parameters | will be displayed as "COP" |
| 4. Low voltage alarm (*)    | will be displayed as "AL"  |
| 5. Phase order alarm (*)    | will be displayed as "Ord" |

(\*) These settings will activate the "Alarms relay"

Using the "↑ ↓" buttons, please select the function you want to define. When finished, please press Enter.

After selecting one of the above mentioned functions, you will get all the values related to the function as described below:

Using the "↑ ↓" buttons, you can change the value.  
 When finished, please press Enter .

Function	Value	Comments
Adr	0-247	Powermeter address
Bud	300-19200 BPS	Setting the Baud rate
COP	O = ODD n = NONE E = EVEN	Parity setting Data field is fixed = 8 bit Start/Stop bit is fixed = 1 bit
AL	0- 400 V	Minimum voltage to activate the "No volt relay"
Ord	yES = Yes nO = NO	Setting the option to activate the "No volt relay" by the phase disorder problem

After finishing all setting use the "↑ ↓" buttons until the "End" the message appears. Please press Enter .

## 6.0 — Communication with UniArt Software

CONTROL APPLICATIONS Ltd's propriety software, "UniArt", is used to Read and Write Registers of the *EINet LTE* Energy & Power Multimeter. Each Item number in the Registers Table is a unique field containing information. The UniArt software manages each Item number as a parameter.

To learn how to set up parameters, refer to the UniArt manual.

To read fields using UniArt:

1. Find the required reading in the MODBUS Registers Table
2. Note the Item Number from the Registers Table
3. Go to the correct File number  
Since the File capacity in UniArt is limited to 128 parameters, the information contained in the EINet LTE fields is stored in several files.  
The File number is determined by the Item number  
File #0 contains Item number 1-128  
File #1 contains Item number 129-256  
File #2 contains Item number 257-384  
File #3 contains Item number 385-512
4. Go to the correct Point number within that file:  
The Point number is determined by the formula:



Item number – [FILE X 128] = Point Number

E.G. 1 If the user wishes to read Voltage Line 2

(Item No 2) by applying the formula:

$$2 - [0 \times 128] = 2$$

File = 0 and Point within that file = 2

E.G. 2 If the user wishes to read 30<sup>th</sup> Harmonics for Volts

Line1 (Item No 330) by applying the formula:

$$330 - [2 \times 128] = 74$$

File = 2 and Point within that file = 74

E.G. 3 If the user wishes to read 7<sup>th</sup> Harmonic for

Current Line 3 (Item No 467)

by applying the formula:

$$467 - [3 \times 128] = 83$$

File = 3 and Point number within that file = 83



## More Examples

E.G. No	Item No	Field Description	File	Point
1	2	Voltage Line 2	0	2
2	330	30 <sup>th</sup> Harmonics for Volts Line1	2	74
3	467	7 <sup>th</sup> Harmonic for Current Line 3	3	83
4	128		0	128
5	129		1	1
6	256		1	128
7	257		2	1
8	384	20 <sup>th</sup> Harmonics for Volts Line 3	2	128
9	385	21 <sup>st</sup> Harmonics for Volts Line3	3	1